

KOS



KOS

# INDEX

## MORPHING COLLECTION

32 Morphing/ Consolle  
36 Morphing/ Bathtubs  
41 Morphing/ Bathtub L. 1500  
42 Morphing/ Steel  
48 Morphing/ Unit  
52 Morphing/ Complements

--

## FARAWAY COLLECTION

54 Faraway/ Vis-à-vis  
58 Faraway/ Shower Program  
60 Faraway/ Basins  
66 Faraway/ Furniture and Complements

--

## AGORÀ COLLECTION

74 Agorà / Bathtub  
76 Agorà / Basin

--

## KAOS COLLECTION

78 Kaos 2  
82 Kaos 1  
84 Kaos 3

--

## GRANDE COLLECTION

86 Grande  
90 Grande angolo  
92 Grande quadra  
94 Grande quadra step

## GEO COLLECTION

96 Geo 180  
102 Geo 180x80  
102 Geo 170x70  
104 Geo 170x70 *free standing*

--

## SOFT

106 Soft

--

## MUSE

108 Muse

--

## AVEC COLLECTION

110 Avec moi  
116 Avec toi  
120 Avec small

--

## KOSMIC

122 Kosmic Z2  
126 Kosmic Z1

--

## ATOLLO

128 Atollo

## GEO SHOWER TRAYS

130 Geo Tray  
132 Geo Tray 80

--

## FLOOR

134 Floor 1  
134 Floor 2

--

## LAB COLLECTION

136 Lab 01 *free standing*  
138 Lab 01 30/50  
140 Lab 02  
142 Lab 03 *free standing*  
144 Lab 03 *deck mounted*

--

## IDROCOLORE®

146 Idrocolore®

--

SCHEDE TECNICHE  
TECHNICAL INFORMATION  
150



– Lifestyle starts with a dream.





– Architectural impact.

























– New moods, new flair.

































# Emotions, surfaces, materials.

Kos intende rispondere alle esigenze più profonde della società: oggi si cerca 'fisicità'. Si vuole toccare, provare emozioni legate al corpo, alla matericità. Questa necessità, tradotta nel linguaggio degli oggetti quotidiani, significa dare spazio a forme da accarezzare, a colori da assaporare, ...ad un'esperienza sensoriale globale. Un ambito che Kos indaga da anni; il brevetto Idrocolore® ne è certamente una delle più manifeste espressioni.

L'Idrocolore® è un sistema brevettato dall'azienda in grado di portare la luce direttamente 'dentro' l'acqua; ciò avviene grazie ad una speciale tecnologia che si avvale di fibre ottiche. Sei colori base, miscelabili a piacere da parte dell'utente tramite la tastiera di comando, illuminano l'acqua o il vapore, colorandoli e riflettendosi attraverso di essi: le vasche o i box doccia divengono enormi fonti luminose.

L'emozione di immergersi in esse è così forte da rimanere impressa a lungo nella nostra memoria; così unica e singolare, da non poter essere paragonata a nulla di conosciuto se non all'impossibile ricordo del grembo materno che ci ha accolto. Non una scelta commerciale, dunque, ma il frutto di una filosofia aziendale, mirata a portare in questo settore 'quell'emozione in più'. Anche le forme dell'intera collezione, morbide e avvolgenti, i materiali, igienici e puri, concorrono alla generazione di sensazioni dolci, coinvolgenti.

Linee essenziali, proporzioni studiate per ottimizzare il rapporto tra ergonomia e forma, cura e attenzione ai dettagli delle finiture: tutto questo identifica il 'Kos Touch', un'esperienza sensoriale e ludica, per il corpo e per la mente.



Kos is meant to meet the highly demanding requirements of society. These days, "physicality" is of the utmost importance. People wish to touch, to experience feelings associated with the body and with materials.

In the language of everyday objects, this need demands shapes you can caress and colors you can taste for an experience that is all-consuming and sensual. It's a context that Kos has been investigating for years; the Idrocolore® patent is an obvious result. Idrocolore® is a patented system that injects light directly into water thanks to a technology based on fiber optics. Six basic colors (which can be mixed as desired using a keypad) illuminate, color and reflect through water or steam. Tubs or shower cabins thus become enormous sources of light, where the excitement of getting in is so strong that it stays with you for a long, long time, and is so unique and remarkable that it cannot be compared with anything you've experienced...except perhaps the unrecoverable memory of our mothers' womb.

In essence, Idrocolore® is not the result of a business decision, but of a corporate philosophy that aims to bring "extra emotion" to this sector.

Even the soft, cozy shapes of the collection and the hygienic, pure materials it is made of contribute to its soft, irresistible sensations.

Simple lines, proportions that balance the relationship between ergonomic design and form, and care and attention to the details of the finishing: all this is the "Kos Touch", a playful, sensuous experience for both body and mind.

# MORPHING

---

## COLLECTION

### Morphing / Consolle

Oggetto di memoria sul piano tipologico e semantico, Morphing/Consolle è allo stesso tempo un prodotto innovativo nel design e nei materiali. Un progetto bagno assolutamente contemporaneo che ammicca ai modelli classici, caratterizzato da un'estetica trasformista e fluida.

While Morphing/Console belongs to the realm of recollections for type and semantics, it is nevertheless innovative in terms of design and materials. A totally contemporary bathroom project which nods at classic models, while being characterised by fluid, mutant aesthetics.

– *Morphing Awards: Honourable Mention Compasso d'Oro 2014*  
*Good Design Award 2011*  
*ADI Design Index 2011*  
*Design Plus 2011*  
*Design Award Bathroom Gold 2010*









# MORPHING

---

## COLLECTION

### Morphing / Bathtubs

Rilettura contemporanea della tipologia classica della 'vasca a piedino', Morphing/ Bath Tub ha un'estetica innovativa, un'ergonomia confortevole, un touch morbido e vellutato. Disponibile anche nella versione bicolore, white and red e white and black, è un prodotto destinato a cambiare per sempre la tradizionale percezione dell'elemento vasca. La versatilità del Cristalplant® ne consente una versione 'pannellata', dall'estetica monolitica e scultorea.

A contemporary reinterpretation of the classic 'bath tub on legs', Morphing/ Bath Tub offers innovative aesthetics, comfortable ergonomics, and a soft and velvety feel. Also available in the two-coloured versions, white and red and white and black, this product is destined to change the traditional perception of the bath tub element for ever. Versatile Cristalplant® has enabled the creation of a 'panelled' version of monolithic, sculptural appeal.













# MORPHING

---

## COLLECTION



## Morphing / Steel

Morphing/ Steel è un sistema di volumi e incastri; complesso, articolato e composito, è un gioco di forme e materiali diversi. Il touch setoso del Cristalplant®, l'assolutezza del metallo e la naturale morbidezza della laccatura dei cassetti, si mescolano e fondono in un unico mobile decostruito: leggerezza e matericità, volumi e sottili linee grafiche definiscono un nuovo sistema bagno contemporaneo ed eclettico.

Morphing/ Steel is a system of modular units; complex, articulated and composite: a play of different forms and materials. The silky touch of Cristalplant®, the strength of metal, and the natural softness of the lacquered drawers are mixed and fused in a unique deconstructed assembly: lightness and texture, 3D forms and thin graphic lines define a new bathroom system of contemporary and versatile appeal.













# MORPHING

---

## COLLECTION

### Morphing / Unit



Morphing/ Unit è un sistema semplice e al contempo versatile, in grado di offrire infinite soluzioni progettuali. Componibile, flessibile e studiato per offrire numerose varianti dimensionali e formali, Morphing/ Unit è composto da mobili a cassettoni, frontali e/o laterali, mobili con piano lavabo integrato, mobili/ colonna.

Moduli per creare composizioni personalizzate; volumi essenziali, per definire landscape architettonici articolati e sempre nuovi.

Morphing/ Unit is a simple yet versatile system, capable of offering infinite project-planning solutions. Modular, flexible, and studied to offer multiple variants of size and form, Morphing/ Unit is composed of cabinets with front and/or side drawer-chests, cabinets with integrated wash-basins, column cabinets. Modules for personalised compositions: linear elements, to achieve complex, ever changing architectural landscapes.









# MORPHING

---

## COLLECTION



## Morphing / Complements

Morphing/ Complements è una linea di complementi d'arredo dall'estetica lineare, fortemente geometrica. Elementi design oriented, per combinazioni funzionali, articolate e uniche; soluzioni spaziali, per ogni tipo di ambiente bagno. Dettagli, profondità e spessori dei mobili Morphing/ Complements sono stati studiati per ottimizzare ogni tipo di spazio.

Morphing/ Complements is a line of furnishing accessories of linear, markedly geometric aesthetics. Design-oriented elements, for functional, complex, unique combinations; special solutions for any type of bathroom ambience. Details, depth and thickness of Morphing/ Complements furnishings have been studied to make the most of any space.





SOIN  
BOUCHE  
EXTRA PUR  
FIGUE

# FARAWAY

---

## COLLECTION

### Faraway/ Vis-à-vis

Faraway/ Vis-à-vis, vasca free standing in Cristalplant®, nasce dallo studio di geometrie organiche, asimmetriche, ibride tra rigore e sensualità. Uno shaping che rimanda alle estetiche della contemporaneità. La sua forma è studiata per indagare nuove ergonomie finalizzate al risparmio energetico e dell'acqua: geometricamente si allarga e si restringe in base al comfort richiesto.

Faraway/ Vis-à-vis, Cristalplant® free standing bath tub, was born from study of organic, asymmetrical geometries, a hybrid mating of rigour and sensuality. A shaping mindful of contemporary aesthetics. Its form explores new ergonomics whilst saving energy and water by geometrically expanding or shrinking to suit the comfort level required.

– Faraway Awards: Honourable Mention Compasso D'Oro 2011  
Design Plus 2011  
ADI Index 2010  
Australian International Design Awards 2010  
EDIDA 2010  
Red Dot Communication Award 2009  
Design Award Bathroom Gold 2009











# FARAWAY

---

## SHOWER PROGRAM

### Faraway 1, Faraway 2

Faraway è ricerca di nuove spazialità per l'ambiente bagno e di nuove flessibilità funzionali per infinite libertà progettuali. Una chiusura doccia semplice nella forma, ma in materiali pregiati, in due versioni dimensionali ed in due versioni funzionali, con braccio singolo o integrato al soffione doccia.

Faraway is the research for a new spatiality in the bathroom ambience and for new functional flexibility, to give infinite freedom for project development.

A shower enclosure with a simple shape but made of precious materials, with two size versions and two functional versions. It offers a basic holding arm or a version with integrated shower head.



Faraway 1



Faraway 2





# FARAWAY

---

## BASINS COLLECTION

Faraway è un kit esperienziale molto flessibile, una collezione componibile e modulare che permette soluzioni spaziali del tutto innovative: nuovi sistemi aggregativi per un ambiente bagno destrutturato, contemporaneo, non convenzionale. Metafora di un viaggio alla scoperta dei sensi, Faraway indaga un nuovo 'mondo wellness', stravolgendo il comune senso del benessere. Aromi, profumi, superfici vellutate, shaping arrotondati, invitano una gestualità morbida e naturale: Faraway propone un bagno nomade, dà forma all'esperienza dei sensi, worldwide.

Faraway is a highly flexible kit of components: a collection that is demountable and modular, making it possible to organise the bathroom space in totally innovative ways, new solutions that create a more relaxed, contemporary, unconventional bathroom environment.

Faraway is the metaphor for a distant journey, to rediscover the senses and explore a new world of wellness, completely different from the usual concept of "wellbeing". With fragrances, aromas, velvety-soft surfaces, and rounded shapes that invite soft, natural caresses, Faraway suggests a nomadic bathroom, and gives physical form to the experience of the senses, anywhere in the world.



# Faraway/ Round

Faraway/ Round è un lavabo free standing in Cristalplant® dall'estetica molto leggera, caratterizzato da un basamento asimmetrico che ne permette una visione e un utilizzo diversificato. Non esiste un punto di vista prioritario ma infinite composizioni spaziali: accostato al muro con rubinetto a parete, con una composizione di mobili laterale e rubinetto a muro o free standing, a centro stanza con rubinetto free standing. Grande libertà progettuale per l'architetto, nuove iconografie per l'ambiente bagno.

Faraway/ Round is a Cristalplant® free standing washbasin of subtle aesthetics, characterized by an asymmetrical base which allows diversified perspectives and uses. It features not a primary point of view but infinite spatial compositions: set against the wall, with a wall-mounted tap; flanked by an assembly of cabinets, centered in the bathroom with free standing or wall mounted tap. Great freedom for the architect's project development, new iconographies for the bathroom environment.







# Faraway/ Square

L'estetica di Faraway/ Square è caratterizzata da un piano geometricamente rigoroso, che nella versione a colonna raccoglie ed ammorbidisce le sue linee divenendo sottile basamento. Nella versione appoggio, Faraway/ Square può essere abbinato a mobili in frassino cotto, generando uno speciale effetto tattile tra la matericità setosa del Cristalplant® e quella naturale dell'essenza del legno. L'esperienza sensoriale è ancora una volta il punto di arrivo di un viaggio alla scoperta del benessere.

Faraway/ Square aesthetics are characterized by a rigorously geometrical top whose lines, in the pedestal version, are gathered and softened in the slender base.

In the deck mounted version, Faraway/ Square can be combined with cabinets made of heat-treated ash wood, generating a special tactile effect through the contrast of the silky smoothness of Cristalplant® with the natural feel of solid wood. Sensory experience is once again the destination of a journey in search of wellbeing.





# FARAWAY

---

## FURNISHING COMPLEMENTS COLLECTION

Faraway è un kit esperienziale, fatto di oggetti belli, dalle forme rilassanti, superfici da toccare. Il calore del frassino cotto, la morbidezza del Cristalplant®, il profumo degli incensi, sono parte integrante e fondamentale del progetto.

Faraway is a kit of components that consists of beautiful things, relaxed shapes, surfaces meant to be touched. The warmth of heat treated ash wood, the softness of Cristalplant®, and the scents of incenses: these are all integral parts to the project.



## Faraway *furniture*



Mobili in frassino cotto, dalle essenze calde e materiche che per contrasto, esaltano il bianco dei lavabi a cui possono essere abbinati.

Heat treated ash wood furniture, of pleasing shades, that enhance the white of the basins to which they can be combined.





# Faraway *furniture*

Una consolle da abbinare al lavabo Square, sempre in frassino cotto, dal caldo colore marrone e dalla superficie levigata, completa la collezione.

A console combined with the Square basin, always made of heat treated ash wood, with a warm brown color and a smooth surface, complete the collection.







## Faraway complements



Faraway presenta anche una serie di complementi d'arredo in acciaio verniciato nei colori bianco o blu sky.

Mensole e specchi modulari, tavolini dall'estetica lineare e leggera; carrelli contenitori colorati, posizionabili sotto i lavabi free standing a consentire nuove libertà progettuali.

The Faraway collection is completed by white or sky blue painted metal complementary objects. Modular shelves and mirrors, tables aesthetically linear and pleasant; container trolleys in multiple colours, positioned under the free standing basins allowing a new planning freedom.



Una punteggiatura elegante  
e colorata per ogni tipo di  
ambiente bagno.

An elegant and colourful  
punctuation for every  
bathroom.



# AGORÀ

---

## COLLECTION

La collezione Agorà rappresenta un perfetto equilibrio tra passato e presente.

Un progetto 'ritrovato' e reinterpretato da Ludovica+Roberto Palomba dove l'ispirazione classica viene attualizzata attraverso i dettagli e i materiali, la tradizione continua nel segno della innovazione.

La vasca e il lavabo hanno un'estetica scultorea. Lo stile senza tempo di un design classico si fonde a materiali di ultima generazione come il Silkstone, caratterizzato da un touch vellutato e da un effetto matt.

Agorà/vasca è un oggetto che ricorda il profilo femminile, la sua estetica è morbida, ma i piedini in metallo, forte richiamo alla vasca classica, sono disegnati ed attualizzati.

Il lavabo a catino, dalle dimensioni importanti, la cui linea disegna un perfetto ovale, è una forma pura e senza tempo, che segue l'impronta dell'acqua e si abbina perfettamente anche al design elegante della rubinetteria più classica.

The Agorà collection achieves the perfect equilibrium between past and present.

A 'rediscovered' project reworked by Ludovica+Roberto Palomba, where classic inspiration is brought right up to date with details and materials, tradition followed through innovation.

The tub and basins have a sculpted look. The timeless style of a classic design blends with new-gen materials like Silkstone, characterised by a velvety touch and matt effect.

Agorà/Bathtub echoes the feminine figure. It has soft curves, but its metal feet, while forming a strong link to traditional bathtubs, have been given a modern design makeover.

The large bowl basin with a perfectly oval shape, is a pure and timeless form that echoes the shape of water and is the perfect partner even for the elegant design of more classic taps.

– Agorà Awards: Good Design Award 2013









## Kaos 2

Icona contemporanea del bagno di design, Kaos 2 è un prodotto assolutamente innovativo: la sofisticata ingegnerizzazione permette di racchiudere i motori sotto il bordo della vasca. L'impressione visiva che ne risulta è di una grande vasca-scultura sospesa, dove è il peso dell'acqua stessa a disegnarne la forma, un bacino organico come un'insenatura naturale levigata in cui il corpo può trovare nuove posture e comodità senza vincoli.

A contemporary icon of design bathrooms, Kaos 2 is a totally innovative product: the sophisticated engineering allows to hide the motors under the tub edges. The visual impression is therefore of a large suspended tub-sculpture whose shape is designed by the weight of the water. An organic basin resembling a smooth, natural inlet where your body can find ideal positions and enjoy new unlimited comfort.

– *Kaos Awards: Design Plus 2003*  
*ADI Index 2003*







Nella versione free standing o ad incasso Kaos 2, per la sue generose dimensioni, può essere vissuta singolarmente o condivisa.

Both in the free standing or built-in version, Kaos 2, thanks to its large sizes, can be experienced all by yourself or shared with someone else.





## Kaos 1



La qualità di questo prodotto sta nell'idea progettuale, nella ricchezza della forma e dei dettagli senza rinunciare ad un'immagine amichevole. Un'estetica semplificata, non ridondante, unitaria per una vasca da cui sono stati eliminati i pannelli di tamponamento laterale, elementi ormai datati.

The quality of this product principally lies in the idea behind its design, as well as in its richness of shapes and details, but without sacrificing its friendly image. A simplified, not overstated aesthetic for a bath tub in which the outdated side panels have been eliminated.





# Kaos 3

Il design come grafica  
contestualizzata nello spazio  
architettonico.  
Volumi e dettagli importanti  
anche nel piccolo...

Eye-catching design in any  
architectural context.  
Form and content, down to  
the tiniest detail...



# GRANDE COLLECTION

---

## Grande



Grande esprime una nuova proporzione visiva per l'elemento vasca. Una vera e propria scultura contemporanea, in cui wellness e piacere estetico si fondono in maniera unica. Grande è un volume puro, proposto in 2 versioni: free standing e semi-incasso.

Offering new visual proportions, the Grande tub is a veritable contemporary sculpture in which well-being and pleasant appearance are combined in a unique way. Grande is a shape of highest purity which is offered in two versions: free standing and semi built-in.

– Awards: *Design Plus 2005*

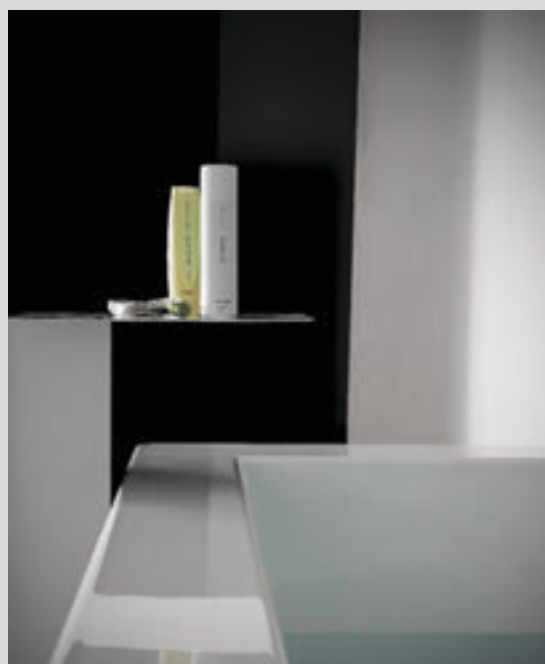









# Grande angolo

Grande angolo è un volume puro, una vasca angolare per non rinunciare, anche in un ambiente bagno più piccolo, ad oggetti di design molto funzionali. Grande angolo esprime una nuova proporzione visiva per l'elemento vasca.

Grande angolo is a three-dimensional shape of the highest purity, an angular tub, that allows to have user-friendly design products, also in a small bathroom. The Grande angolo is designed with proportions never seen before in a tub.

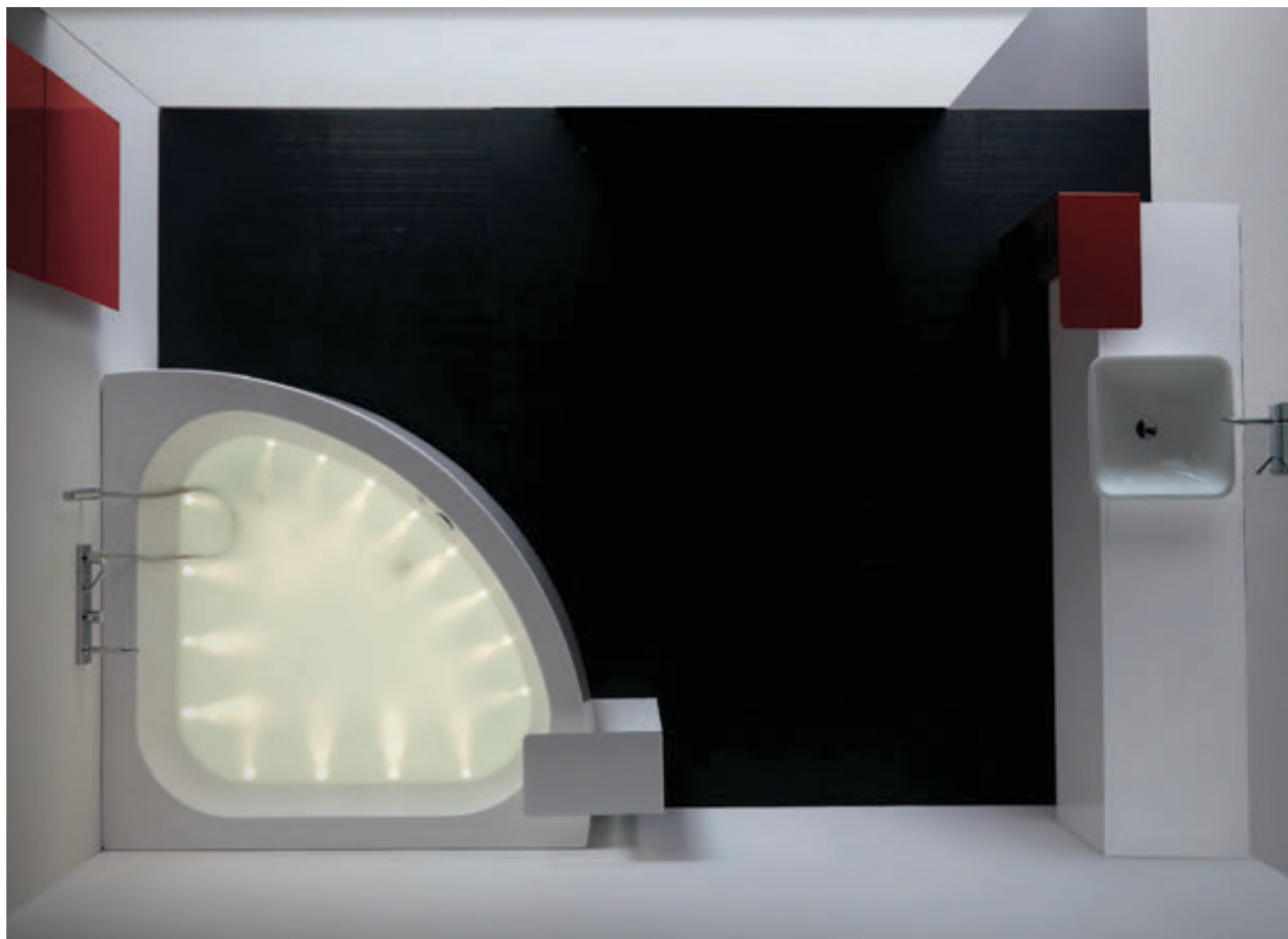



# Grande quadra

Grande quadra è perfetta per ambienti molto grandi, anche limitrofi al bagno ed esprime una nuova proporzione visiva dell'elemento vasca.

Grande quadra is particularly suitable for very big rooms, even near bathrooms and states a new visual porportion of bathtubs.





# Grande quadra step

Grande quadra step è frutto di una suggestione antica, richiama gli ambienti termali romani. Il gradino-sedile, ricorda infatti figurativamente l'antico 'invito all'immersione' delle terme romane.

Grande quadra step, inspired by an ancient fascination, the one related to the roman thermae. The step-seat is a reminiscent of the ancient 'invitation to immersion' into the thermal baths.







## Geo 180

La sua forma 'primitiva' a catino, richiama alla memoria l'immagine di antiche fonti.

Geo 180 fa parte di una famiglia di prodotti che reinventano il progetto sul piano tipologico. Questo prodotto, per la sua linea estremamente particolare ed unica, è in grado di conferire un carattere speciale ad ogni tipo di ambiente, ricreando un'atmosfera quasi mistica.

Its 'primordial' basin-shape reminds ancient fonts.

Geo 180 is part of a family of products that reinvent different types of design. Thanks to its unique and innovative shape, this product is able to give a special and pleasant atmosphere to every kind of environment, creating like a mystic and really evocative ambience.

– Awards: *Design Plus 2007*  
*Grand Design Etico 2008*



*Outdoor Wellness*







Geo 180 è disponibile nelle versioni filo piano, incasso e free standing.

Geo 180 can be available in the flush floor version, in the built-in version or in the free standing version.



## Geo 170x70, Geo 180x80

Seppur progettate in dimensioni contenute, Geo 170x70 e Geo 180x80 dedicano all'acqua uno spazio ampio e confortevole: il loro ingombro si riduce grazie all'assottigliarsi dei bordi, che, come un nastro sottile, definiscono i limiti della vasca stessa.

Although they have been designed upon a smaller scale, Geo 170x70 and Geo 180x80 have dedicated a large and comfortable space to water. Their size seems smaller than it actually is in reality due to their slim edges that, much like a thin ribbon, delineate the very edges of the tub.







# Geo 170x70 Free Standing

Monolitica e importante per le sue linee rigorose e sensuali, GEO 170x70 FREESTANDING ha dimensioni molto contenute e si adatta perfettamente ad ogni tipo di spazio.

La compattezza della parte esteriore si fonde alle curve morbide della sezione interna, generando un progetto essenziale e al contempo ricercato, che ne esalta il carattere geometrico.

Monolithic and important, with its rigorous and sensuous lines GEO 170x70 FREESTANDING has very limited dimensions and adapts perfectly to ambiances of any size.

The compact outer shell blends in with the soft curves of the inner shell, generating a form that is at once essential and sophisticated, heightening the geometric appeal of this project.





## Soft



Soft è un prodotto dal design semplice e funzionale, ideale per ogni tipo e dimensione di ambiente bagno.

Soft is a product with a simple, functional design that is ideal for bathrooms of any type or size.



## Muse

La vasca free standing Muse, pensata per il bagno contemporaneo, si propone come una vera e propria scultura plasmata da linee morbide e delicate, da esibire al centro della stanza.

Come un abbraccio accogliente e rassicurante, il suo ovale invita ad entrare. Il suo interno, ampio ed ergonomico, permette di dedicare un lungo momento alla cura di sé.

Concepita come un guscio dagli spessori sottili, presenta un design essenziale ed un effetto materico originale dalla piacevole tattilità, grazie all'utilizzo del Silkstone.

The free-standing Muse bathtub is designed for the contemporary bathroom and stands out as a real sculpture moulded by soft delicate lines, the perfect centrepiece for the room.

Like a warm, reassuring embrace, its oval is an invitation to enter. Its generous ergonomics make it ideal for long pampering sessions. Conceived as a fine shell, it has essential design and original solidness that feels good to the touch, thanks to use of Silkstone.



## Avec Moi

135x90xh 230 cm

Architettura e design, macro e micro scala, Avec riprende la complessa semplicità di una "glass house". Un micro padiglione domestico trasparente, molto semplice ed immediato nella sua percezione visiva, molto complesso nel suo sviluppo tecnico. Avec Moi è un box doccia multifunzione in alluminio e vetro per uso singolo.

Architecture and design, macro and micro, Avec recalls the complex simplicity of a glass-house. A micro home version of the glass exhibition halls, transparent, very simple and immediate in its visual perception, but at the same time extremely complex in its technical design. Avec Moi is a single-user multifunctional shower box made of aluminum and glass.















# Avec Toi

180x90xh 230 cm

Assoluta leggerezza fisica ed estetica per questa declinazione del box doccia multifunzione. Per i setti sottili Avec ricorda l'architettura minimalista, per il materiale i più moderni oggetti di elettronica. Kos piega il design al servizio del wellness e nello stesso tempo lo rende contenitore interattivo di informazioni. Avec Toi grazie alle sue dimensioni extra si presta per l'utilizzo con più utenti contemporaneamente.

Total and complete lightness - both physical and aesthetic - in this ultimate expression of the multi-function shower box. In its ultra-thin elements, Avec recalls the minimalist style of architecture, but in terms of its components, the most modern features offered by electronics. Kos adapts design to serve the needs of wellness and, at the same time, adds interactive electronic technology. Avec Toi thanks to its extra dimensions is suitable for contemporary multi-users.





L'innovativa struttura in alluminio permette di ridurre spessori e dimensioni delle pareti generando una sofisticata cellula di benessere.

The innovative aluminum structure makes it possible to reduce the thickness of the supports and dimensions of the panels, creating a light and sophisticated wellness area.





# Avec Small

120×80×h 230 cm

Una versione di dimensioni contenute per rispondere sempre ad ogni esigenza progettuale.

A smaller-sized version to be always able to answer every project requirement.





## Kosmic Z2

180x129xh 220 cm

Kosmic Z2 è il nuovo modo di concepire la doccia. Le ampie vetrate ed i volumi generosi ed unitari si rifanno alle architetture contemporanee ed ai segni grafici più attuali.

Kosmic Z2 is a new way of conceiving the shower. The broad expanses of glass and large, unitary shapes are inspired by contemporary architecture and the latest, up-to-date decorations.



Kosmic Z2 è molto diverso da tutti gli altri box in commercio sia per l'impatto visivo sia per il sistema costruttivo degli elementi. Provate ad immaginare il beneficio della cromoterapia unita all'idromassaggio o al bagno turco. Il nuovo lusso incomincia qui.

Kosmic Z2 is radically different from other shower cabins on the market because of its great visual impact and unique construction. Imagine the benefits of color therapy combined with hydromassage or a Turkish bath: today's new luxury begins here.





# Kosmic Z1

129x129xh 220 cm

Pensato come un'architettura nell'architettura, Kosmic attraverso le sue vetrate permette al panorama domestico di divenire panorama architettonico. Kosmic Z1 è accessorato con bagno turco, l'antico sistema per depurarsi dagli stress quotidiani, e le ampie superfici vetrate, garantendo il continuo contatto visivo con l'esterno, eliminano la spiacevole sensazione di chiuso che contraddistingue prodotti similari.

Developed to be architecture within architecture, Kosmic and its broad expanses of glass enable the domestic panorama, to become an architectural panorama. Kosmic Z1 is equipped with Turkish bath, the ancient way to eliminate everyday stress, and its large glasses guarantee a continuous view of the outside and eliminate that unpleasant feeling of being "closed in" which is typical of similar products.







# ATOLLO

---

## Atollo

120x80xh 228 cm

Atollo permette una vera e profonda rigenerazione, da viverci anche nel proprio ambiente domestico: ciascuno di noi può riappropriarsi del proprio benessere quotidiano, dedicare la 'giusta' attenzione a se stesso e al proprio wellness.

Atollo allows a deep and real regeneration, that any user can 'live' in his own house: all of us may regain possession of our own wellness and take the well-deserved care of ourselves.



Il box multi-funzione Atollo è una piccola 'architettura domestica' accessoriata con i sistemi Idrocolore®, bagno turco, getti per massaggio dorsale e soffione doccia.

The multifunctional shower cabin Atollo, is like a little 'domestic architecture', accessorized with Idrocolore® system, turkish-bath, central shower head, jets for dorsal massage.



# GEO

---

## SHOWER TRAYS

### Geo tray

Progetto ispirato a forme geometriche assolute, Geo tray ha linee morbide e sinuose, definite da una sottile fenditura che funge al contempo da scolo dell'acqua e profilo dell'oggetto stesso. Installabile anche a filo-pavimento, Geo tray indaga nuove relazioni con lo spazio, esaltando la continuità del segno architettonico dell'orizzonte domestico.

A design which has been inspired by absolute geometrical shapes, Geo tray has been developed with soft, yet winding lines, defined by a subtle cleft, acting both as a draining of the water and a profile of the object itself. Geo tray presented also in the flush floor version, explores new relationships with the space available and exalts the continuity of architectural design within the domestic landscape.





# Geo tray 80

Anche nella versione circolare forma e materiale si esaltano vicendevolmente, restituendo il giusto valore simbolico al quotidiano momento rigenerante della doccia.

Also in the circular version shapes and materials highlight each other and restore the symbolic and ritual value that takes place at the daily regenerating moment of having a shower.

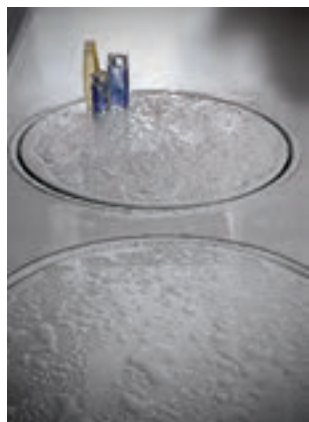



# FLOOR

## Floor 1, Floor 2

Piatti doccia in Cristalplant®, con struttura di chiusura in acciaio lucido e vetro temperato. Possono essere montati ad incasso o a filo pavimento.

Shower trays made of Cristalplant®, with closing structure made of polished stainless steel and tempered glass. They can be installed in a flush floor version or in a built-in version.

– Awards: *Design Plus 2005*

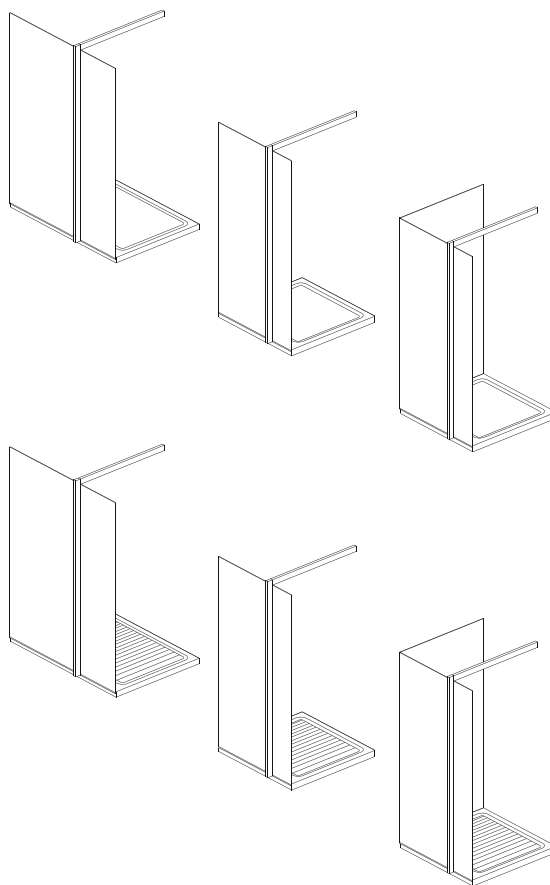





# LAB

---

## COLLECTION



### Lab 01 *free standing*

Scultoreo, fluido, architettonico, nella forma e nel materiale (Pietraluce®), Lab 01 coniuga in sé bellezza e energia, in un primigenio gioco di forze ed equilibri. Un touch dolce e delicato che invade i nostri sensi.

Sculptural, with fluid and sinuous lines, natural in both form and material (Pietraluce®), Lab 01 blends beauty and energy in an eternal play between force and equilibrium. A soft, delicate touch that pervades the senses.



## Lab 01 30/50

Lab 01 è da ora disponibile anche nelle versioni da appoggio, con due differenti altezze.

Lab 01 is now available also in the deck mounted version, with two different heights.





# Lab 02

Free standing, sospeso o da appoggio, in versione single o twin Lab 02 offre un'ampissima versatilità funzionale. Le sue forme geometriche e il materiale (Cristalplant®) conferiscono scultoreità ad ogni tipo di ambiente bagno.

This free standing, deck mounted or wall-mounted washbasin is available in single or twin Lab 02 versions for maximum versatility. The geometric form and material (Cristalplant®) will bring a sense of movement to any bathroom.

– Awards: *Design Plus 2009*





## Lab 03 *free standing*

Complesso, leggero e al contempo materico, Lab 03 è un vero e proprio progetto di architectural-design. La sua geometria purissima, addolcita da curve morbide ed arricchita da una maniglia porta salviette integrata nella forma, lo rende un prodotto assolutamente contemporaneo. Uno shaping ed un materiale (Cristalplant®) innovativi, per una casa moderna e internazionale.

Imposing and complex, while at the same time light and contemporary in style, Lab 03 is the result of a true architectural and design project. Its totally essential lines, softened by the sensually-curved edges and enriched by a towel holder handle integrated in the shape, give this model its totally contemporary look. Innovative shape and material (Cristalplant®) for today's international domestic setting.

– Awards: *Compasso d'Oro 2011*  
*ADI Index 2009*

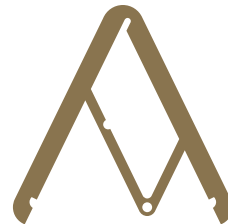

XXII Compasso d'Oro ADI

### LAB 03

Vincitore del XXII Compasso D'Oro ADI  
XXII Compasso D'Oro ADI Award winner

design Ludovico+Roberto Palomba

KOS





## Lab 03 *deck mounted*

Un catino da appoggio dalla forma semplice ed elegante, curato in ogni particolare, in morbido e prezioso Corian®.

A deck mounted basin with a simple and elegant shape. It is very accurate in details and made of soft and precious Corian®.





# ≡ IDROCOLORE®

---

Ogni colore porta un effetto benefico specifico sull'equilibrio psicofisico. Forma e funzione, il bagno sarà una vera sensazione di piacere unita al beneficio reale della cromoterapia. In questo momento qualcuno nel mondo si spoglia, spegne la luce e sta per fare il bagno. Idrocolore® Kos per la cromoterapia totale e massaggio blower per un benessere reale.

Every colour has a specific beneficial effect on psychophysical well-being. Form and function are combined to offer something that is truly new. Having a bath will be a really pleasant experience that is combined with the genuine benefits of chromotherapy. At this very moment, someone in the world is undressing, turning off the light...preparing to have a bath. Idrocolore® by Kos for total chromotherapy and blower massage, offers true well-being.



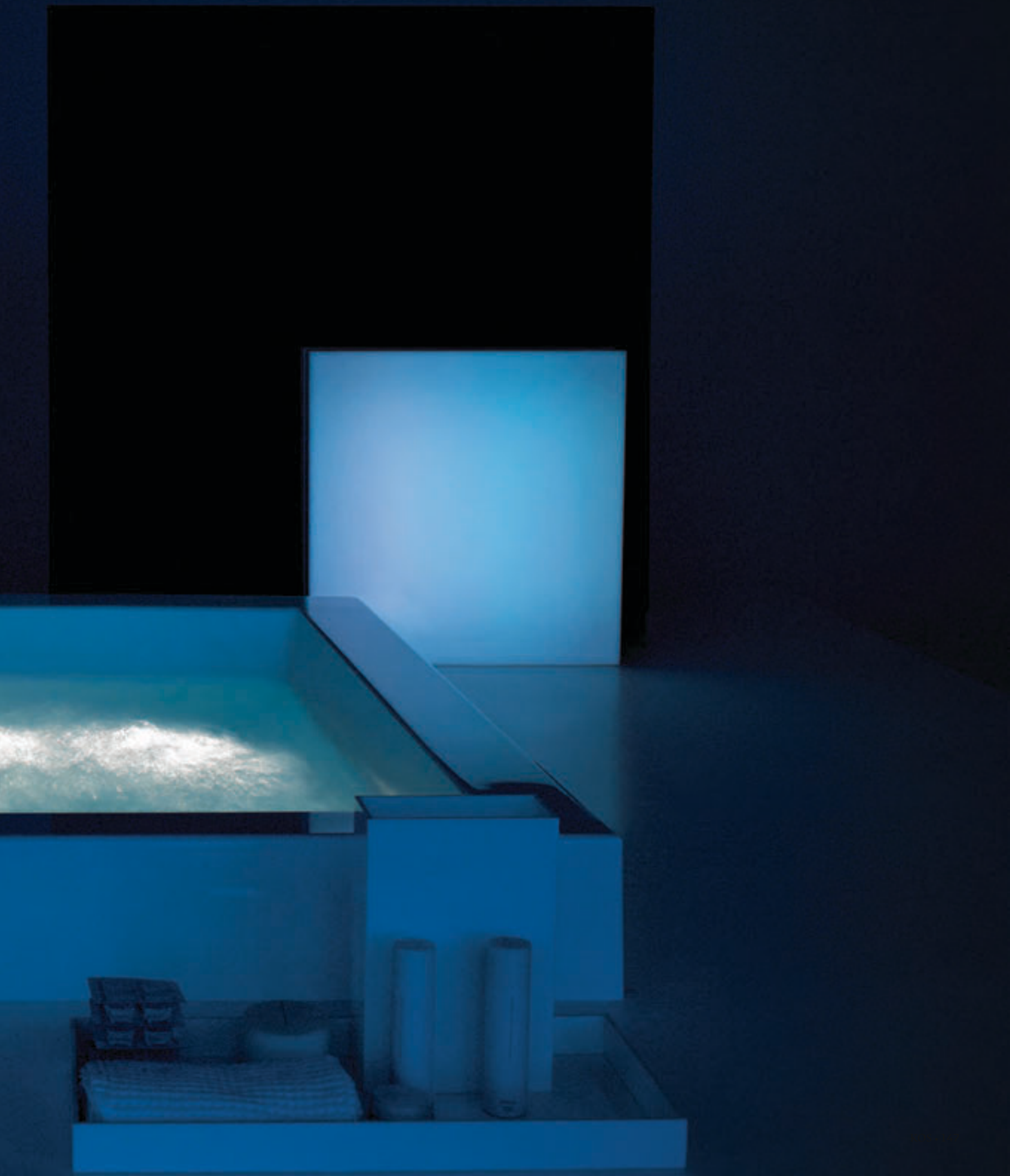

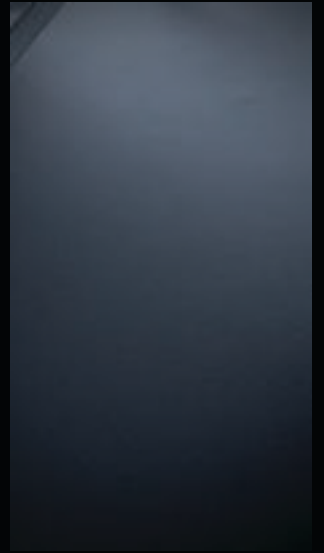



≡ SCHEDE TECNICHE  
TECHNICAL INFORMATION

---





Morphing console

32, 34, 35

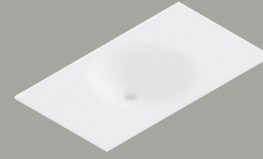
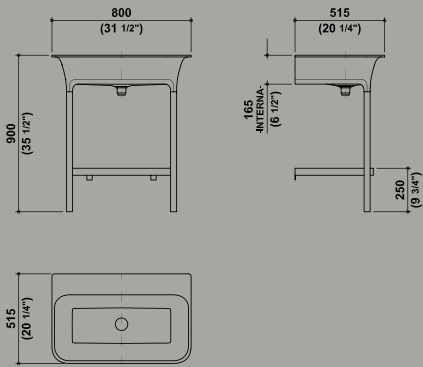

Morphing top con lavabo integrato\_top with integrated washbasin

42, 43, 45, 49, 50

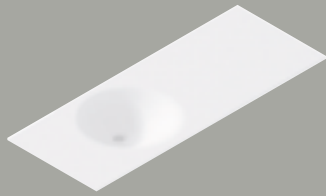
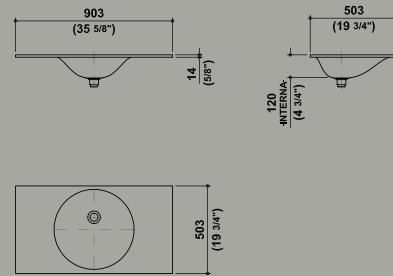

Morphing top con lavabo integrato\_top with integrated washbasin

44, 46, 47, 48, 49, 51

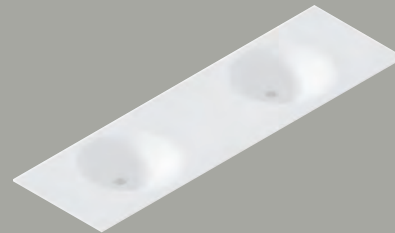
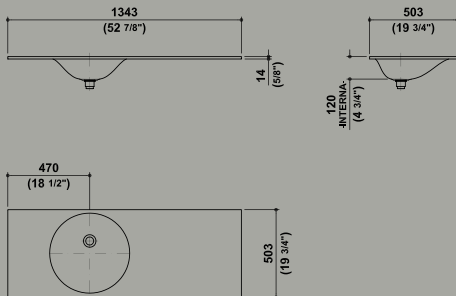

Morphing top con lavabo integrato\_top with integrated washbasin

48

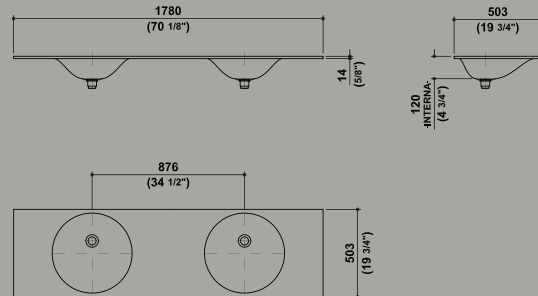

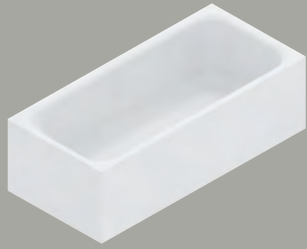

Morphing vasca pannellata\_bath tub panelled version

37, 52, 53

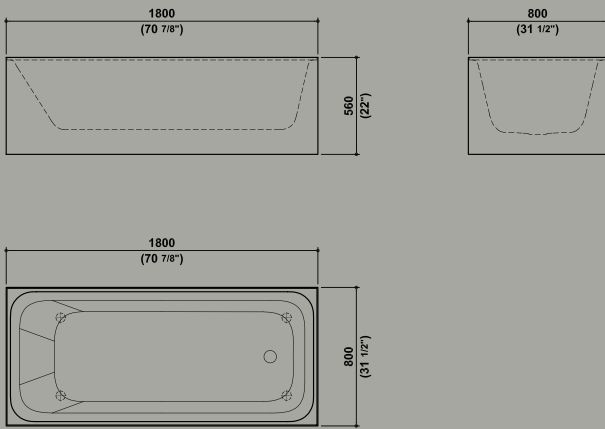

Morphing L. 1800 vasca free standing\_free standing bath tub  
Morphing L. 1500 vasca free standing\_free standing bath tub

33, 38, 39, 40, 41, 43

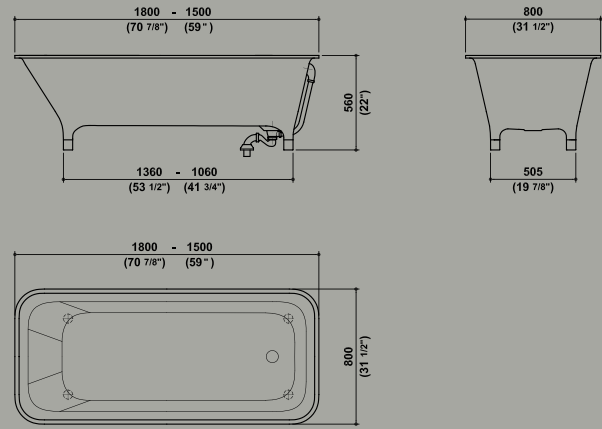

Morphing/steel mobile con lavabo integrato e cassetto  
console with integrated washbasin and drawer

42

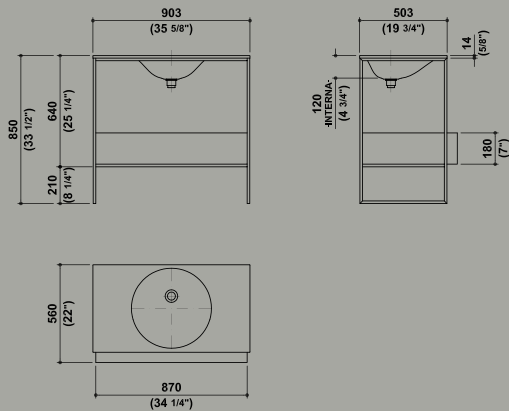

Morphing/steel mobile con lavabo integrato e cassetto  
console with integrated washbasin and drawer

43, 45

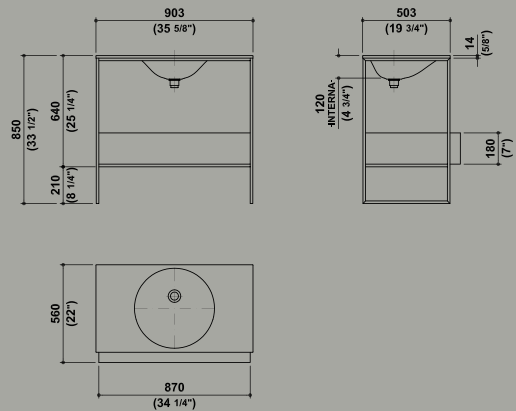

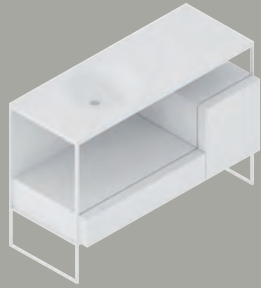

Morphing/steel mobile con lavabo integrato, cassetto e cassettone  
console with integrated washbasin and drawers

46, 47, 48

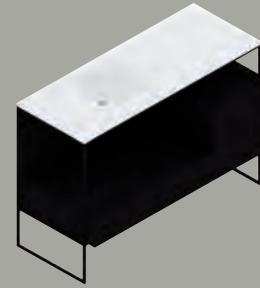
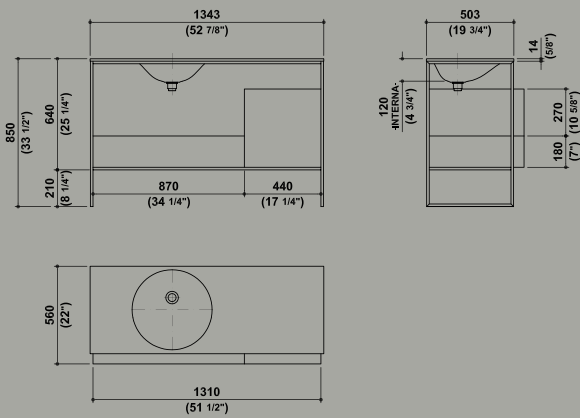

Morphing/steel mobile con lavabo integrato, cassetto e cassettone  
console with integrated washbasin and drawers

44

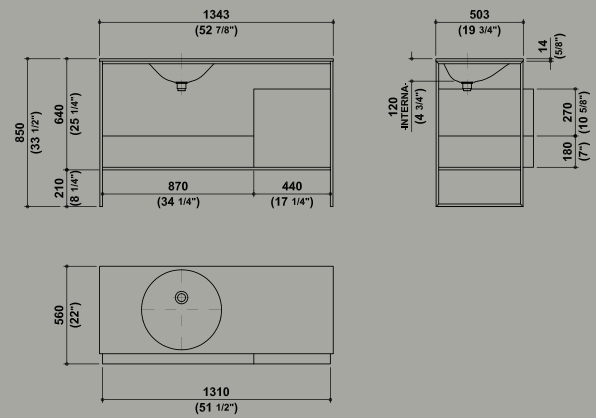

Morphing/unit mobile sospeso con lavabo integrato  
wall-mounted under-cupboard with integrated washbasin

49, 50

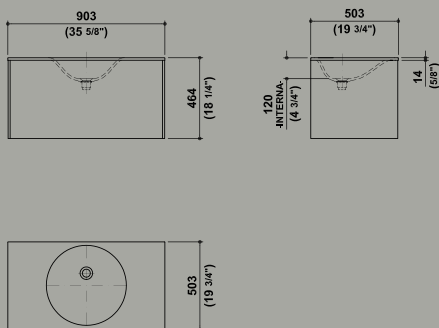

Morphing/unit mobile sospeso con cassettone  
wall-mounted base unit with pull-out drawer

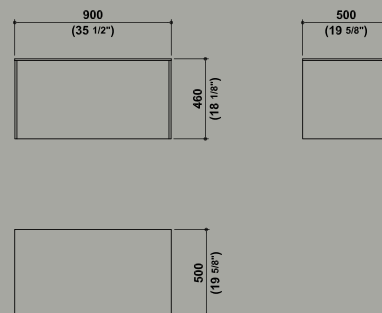

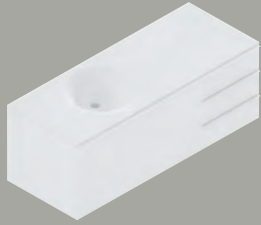

Morphing/unit mobile sospeso con lavabo integrato  
wall-mounted under-cupboard with integrated washbasin

49, 51, 53

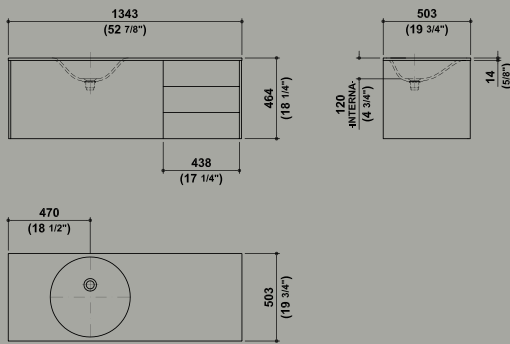

Morphing/unit mobile sospeso con cassettone e cassetteria  
wall-mounted base unit with pull-out drawer and 3 drawers

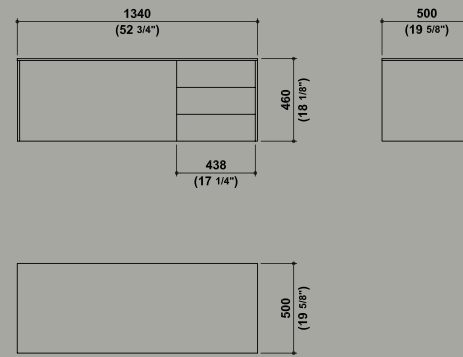

Morphing/unit mobile sospeso con doppio lavabo integrato  
wall-mounted under-cupboard with integrated double washbasin

48

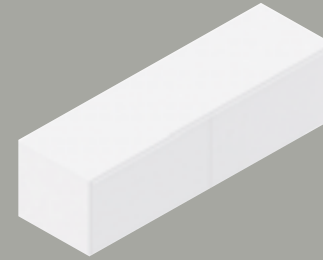
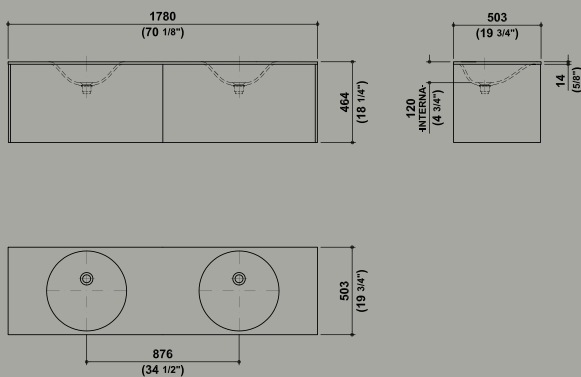

Morphing/unit mobile sospeso con doppio cassettone  
wall-mounted base unit with 2 pull-out drawers

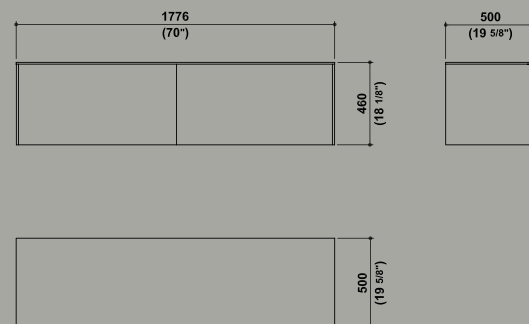



Morphing/unit colonna sospesa con anta  
wall unit

51, 53

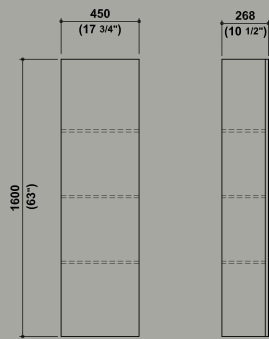

Morphing/complements pensile a giorno con fondo a specchio  
wall unit with mirror

43, 50, 52, 53

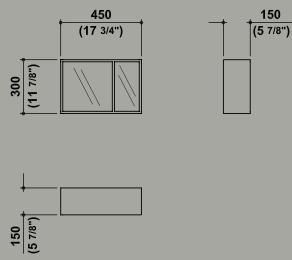

Morphing/unit colonna sospesa con anta a specchio  
wall unit with mirrored door

48

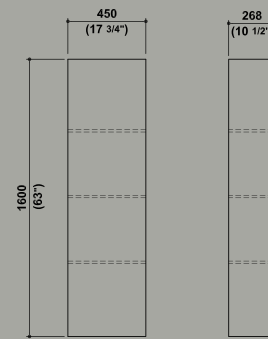

Morphing/complements pensile a giorno con fondo a specchio  
wall unit with mirror

43, 50, 52, 53

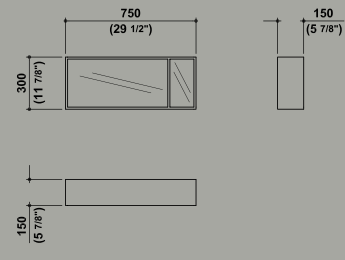



Morphing/complements pensile a giorno con fondo a specchio  
wall unit with mirror

50, 52, 53

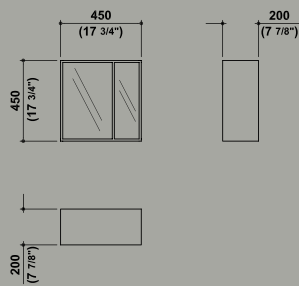

Morphing/complements pensile con anta  
wall unit

43, 50, 52, 53

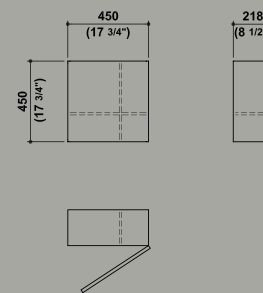

Morphing/complements porta salviette in metallo verniciato  
metal towel holder

43, 52

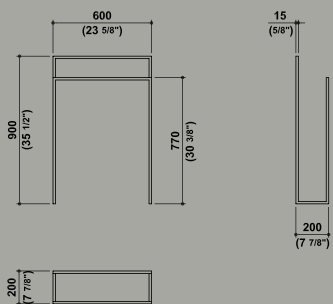

Morphing/complements specchio in metallo verniciato  
mirror in painted metal

33, 34, 45

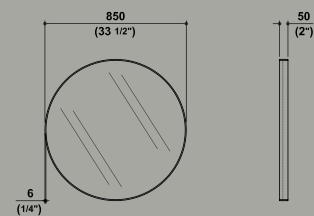



Faraway round free standing

55, 61, 62, 63, 73

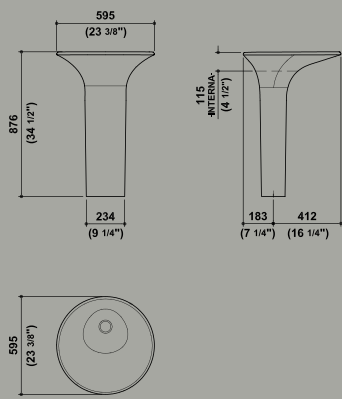

Faraway square

65

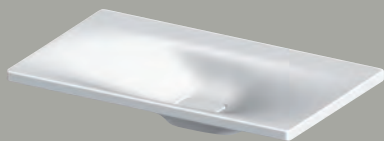
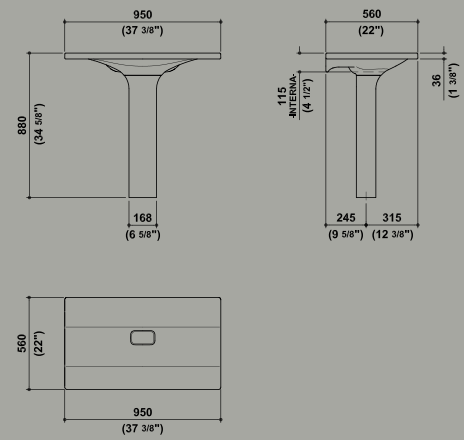

Faraway square da appoggio \_ square deck mounted

64, 70, 71

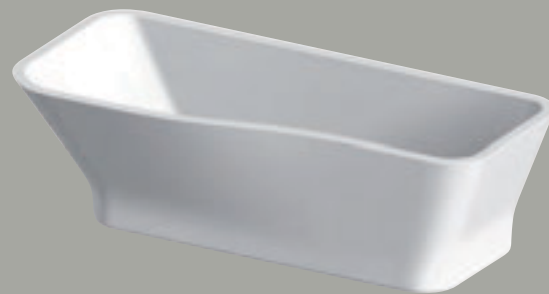
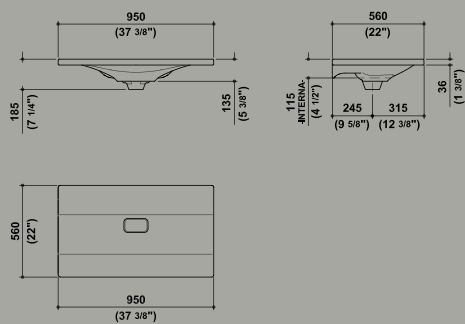

Faraway vis-à-vis

55, 56, 57

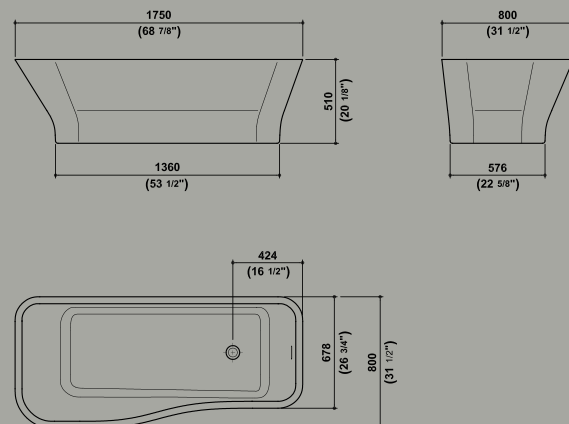



Faraway sistema doccia \_ shower system  
 disponibile anche senza soffione \_ available also without shower head

58, 59

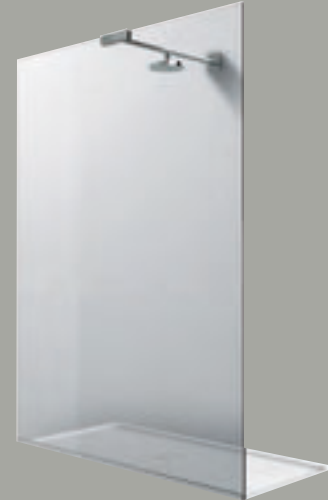
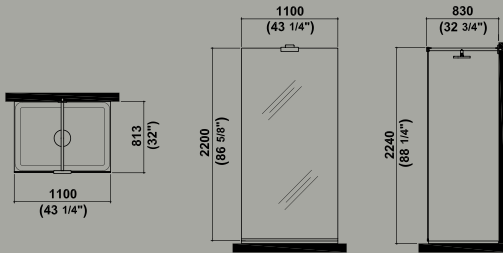

Faraway sistema doccia \_ shower system  
 disponibile anche senza soffione \_ available also without shower head

58, 59

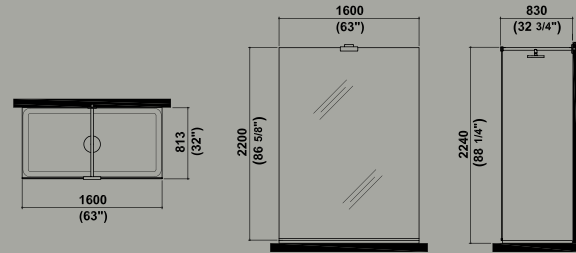

Faraway tavolino rotondo \_ round small table

59, 65, 73

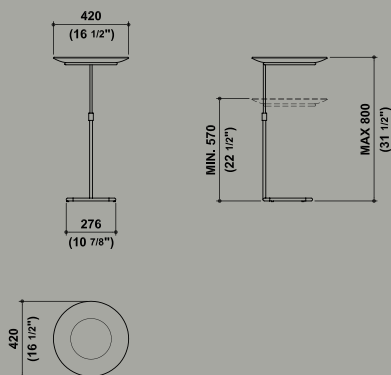

Faraway tavolino in metallo verniciato \_ small table in painted metal

59, 72

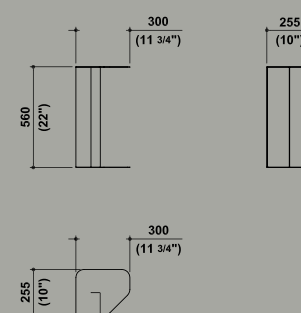





Faraway mensola in metallo verniciato \_ shelf in painted metal (45 cm)

67, 72

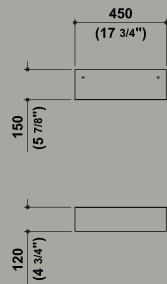

Faraway mensola in metallo verniciato \_ shelf in painted metal (120 cm)

67

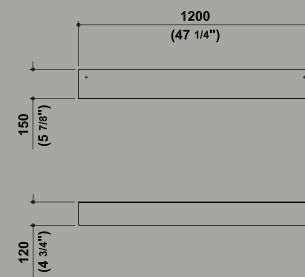

Faraway carrello in metallo verniciato \_ trolley in painted metal

62, 73

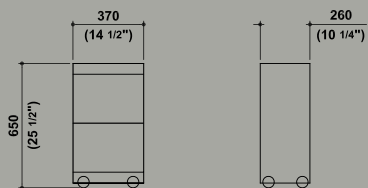

Faraway specchio in metallo verniciato \_ mirror in painted metal

54, 61, 63, 67, 72

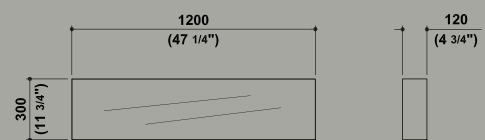

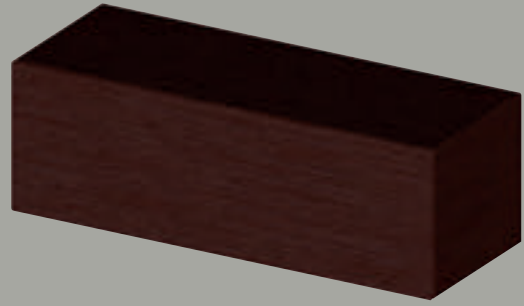

Faraway mobile in legno aperto \_ open wall-hung wood furniture

Faraway mobile in legno con anta \_ folding wooden furniture

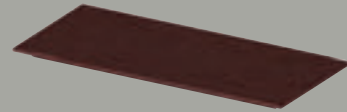
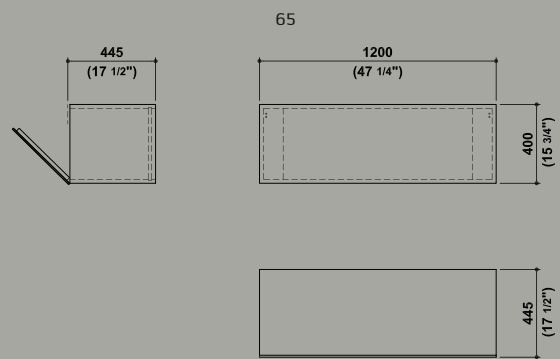
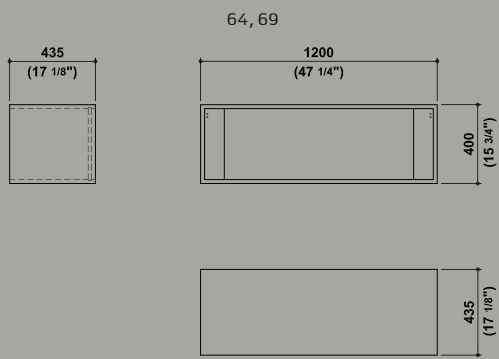

Faraway console in legno \_ wooden console

Faraway mensola in legno per vis-à-vis \_ wooden shelf for vis-à-vis

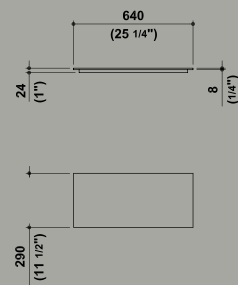
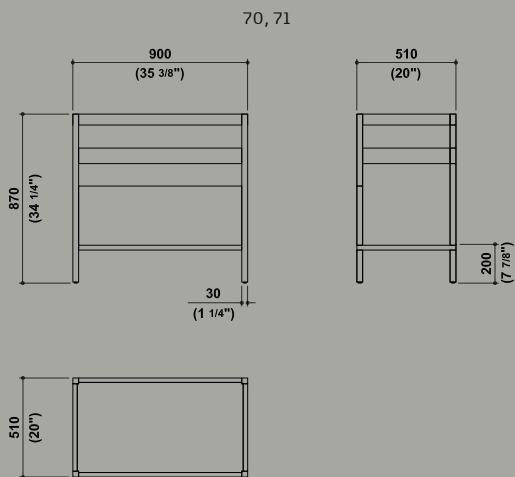

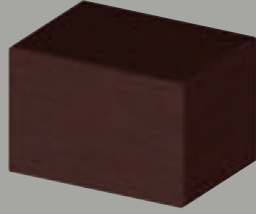

Faraway mobile in legno con anta \_ folding wooden furniture

68, 69

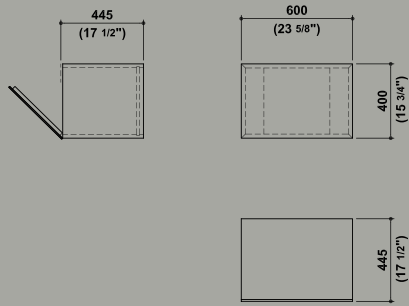

Faraway mobile in legno con anta \_ folding wooden furniture

69

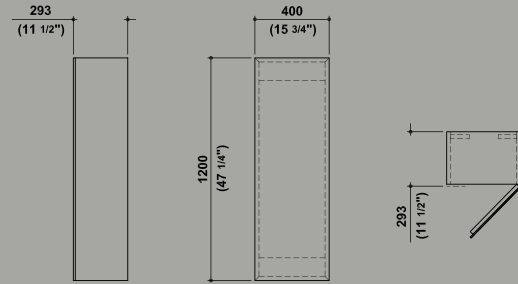

Agorà vasca free standing \_ free standing bath tub

75

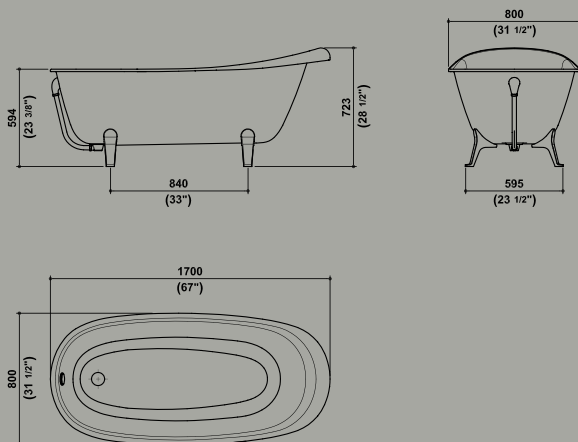

Agorà lavabo da appoggio \_ deck mounted washbasin

76, 77

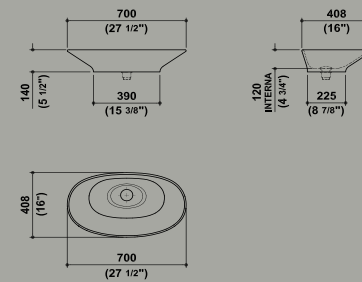



Lab 01 free standing

136, 137

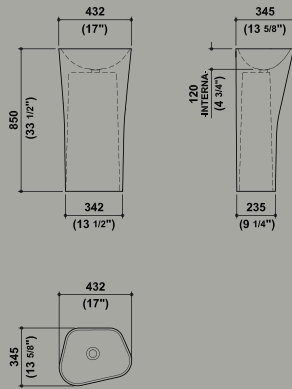

Lab 01 da appoggio \_ deck mounted

139

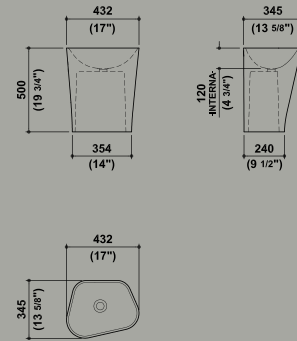

Lab 01 da appoggio \_ deck mounted

138

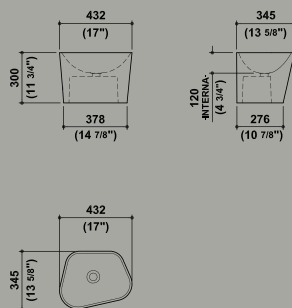

Lab 02 free standing

141

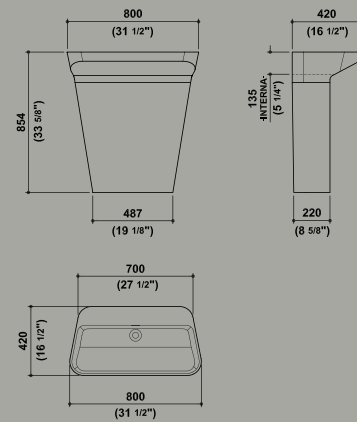

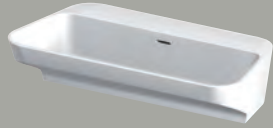

Lab 02 sospeso/appoggio \_ wall mounted/deck mounted

140

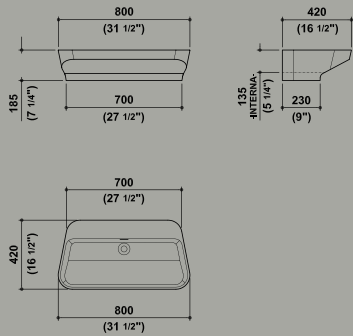

Lab 03 free standing

142, 143

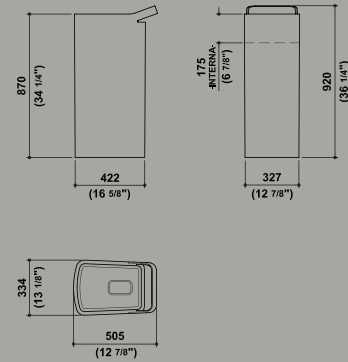

Lab 03 da appoggio \_ deck mounted

144, 145

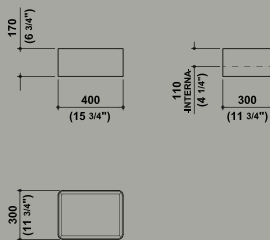



Kaos 1 free standing

83

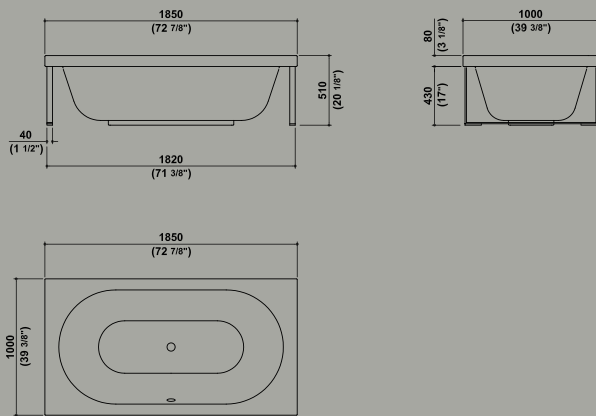

Kaos 1 incasso \_ built-in

82

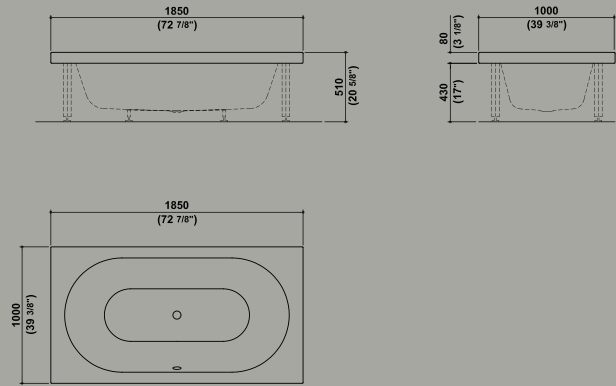

Kaos 2 free standing

79, 80

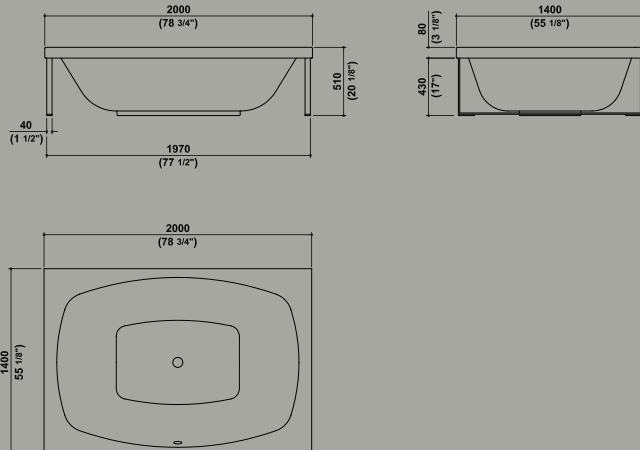

Kaos 2 incasso \_ built-in

81

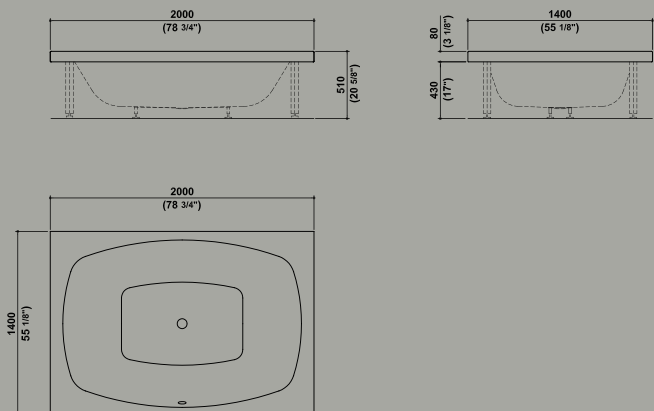



Kaos 3 free standing

84

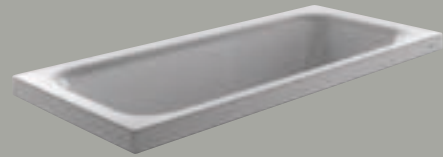
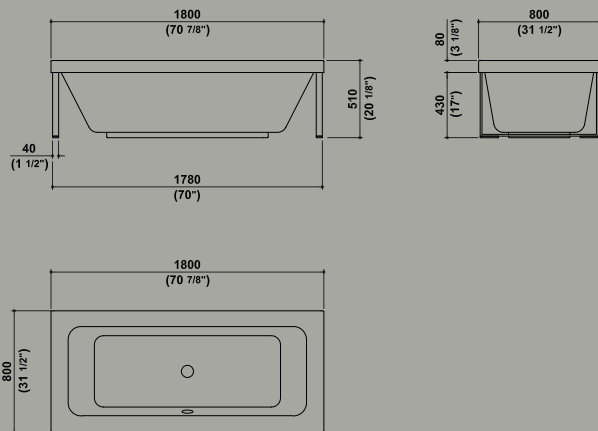

Kaos 3 incasso \_ built-in

85

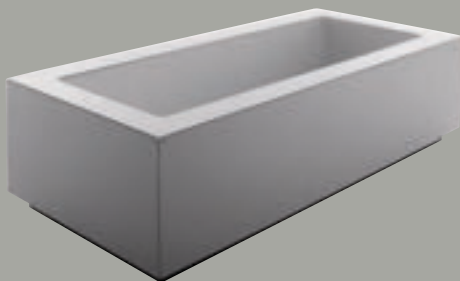
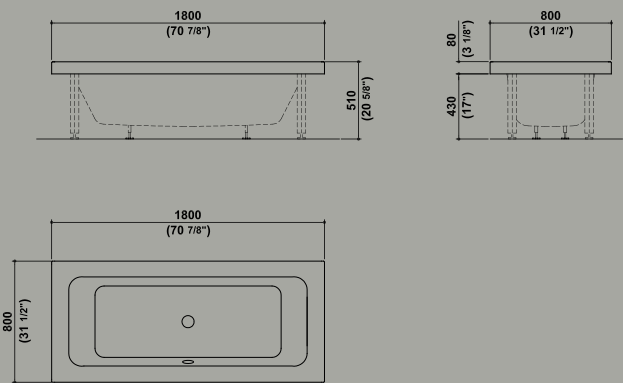

Grande free standing

86, 87

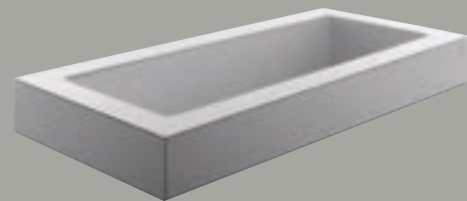
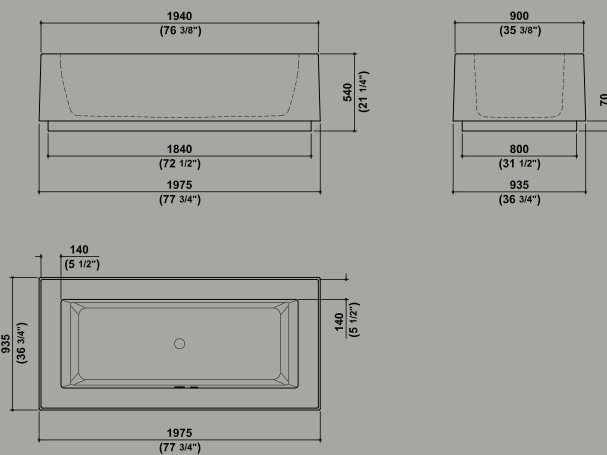

Grande semi incasso \_ semi built-in

89

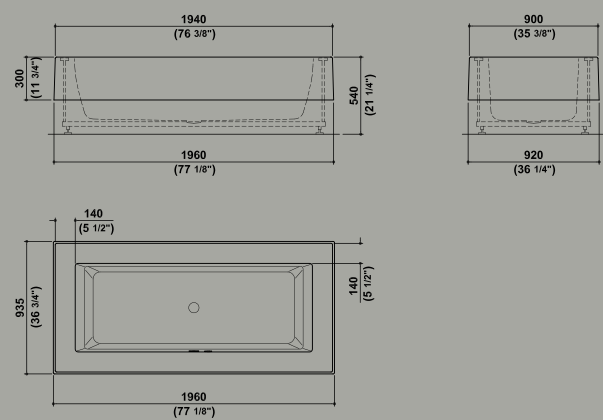



Grande quadra step

94, 95

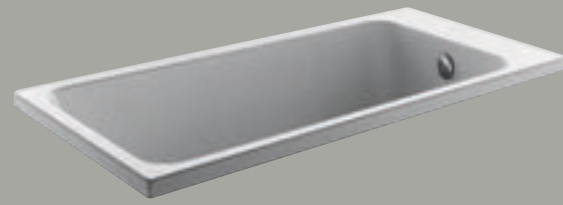
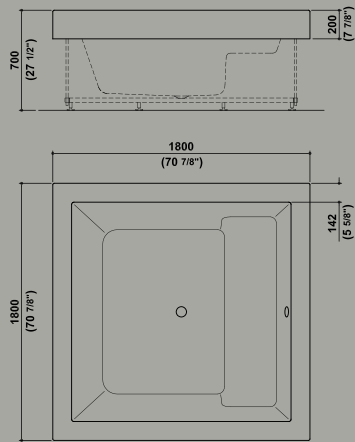

Soft

106, 107

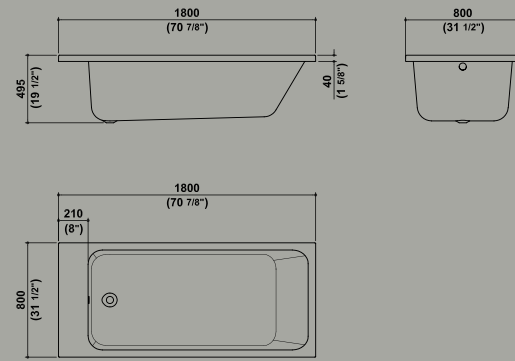

Geo 180 incasso \_ built-in

100, 101

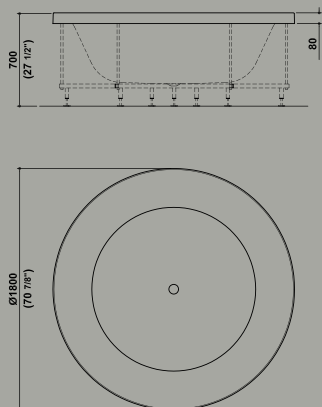

Geo 180 free standing

97, 98, 99

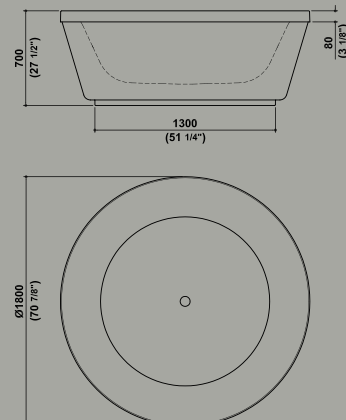





Grande angolo

90, 91

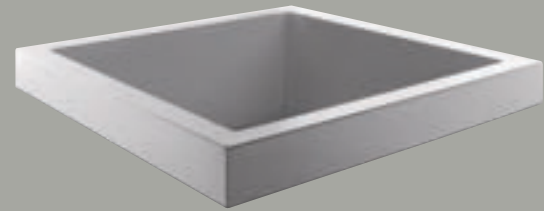
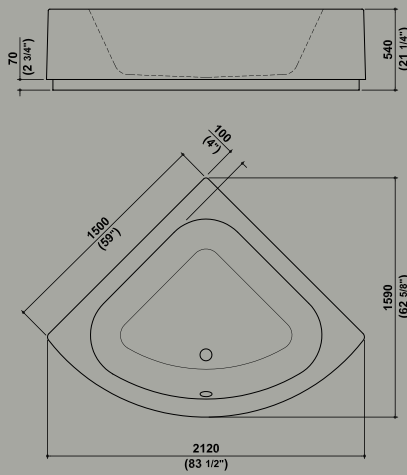

Grande quadra

93

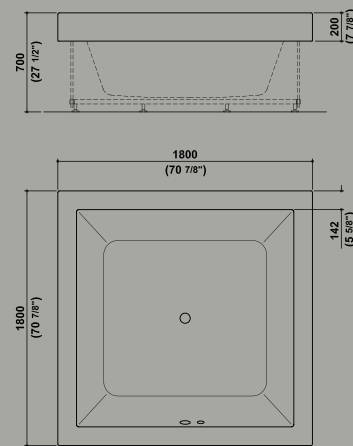

Grande quadra Miami

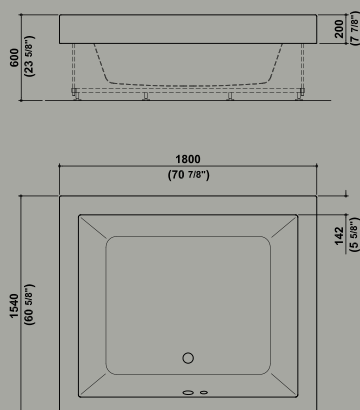

Geo 170x70 incasso \_ built-in  
Geo 180x80 incasso \_ built-in

102, 103

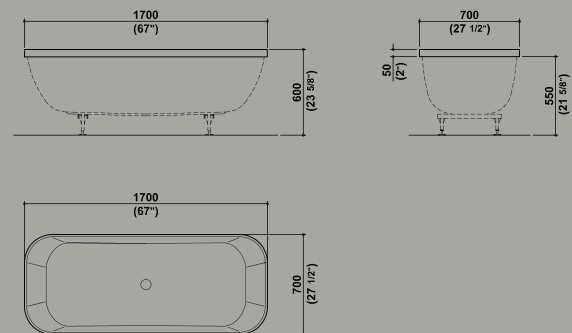



Geo 170x70 free standing

104, 105

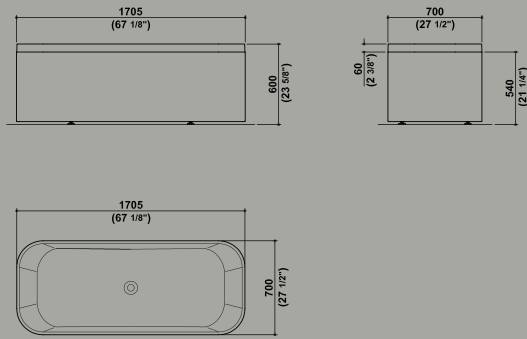

Muse free standing

109

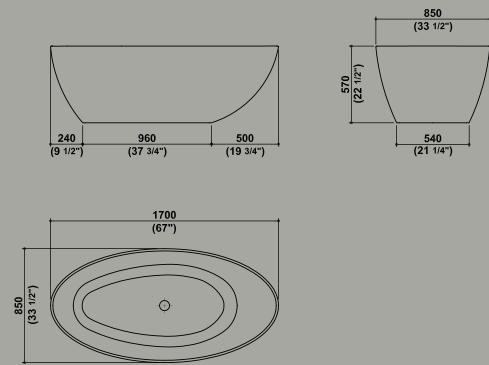



Kosmic Z1 angolo sx/dx e parete \_ left/right hand and back panel to wall

127

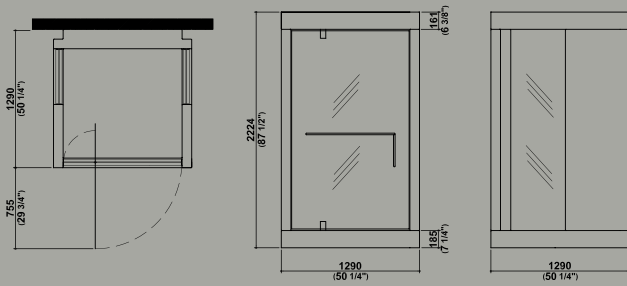

Kosmic Z2 angolo sx/dx e parete \_ left/right hand and back panel to wall

123, 124, 125

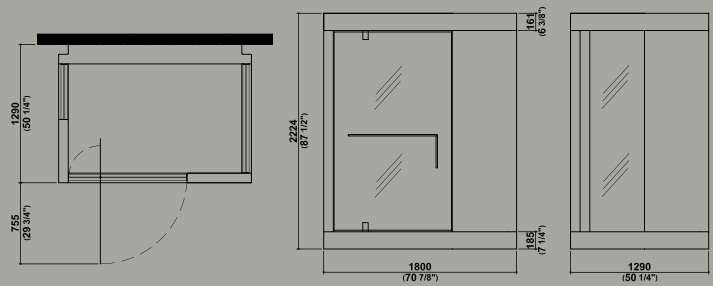

Atollo sx/dx \_ left/right hand

128, 129

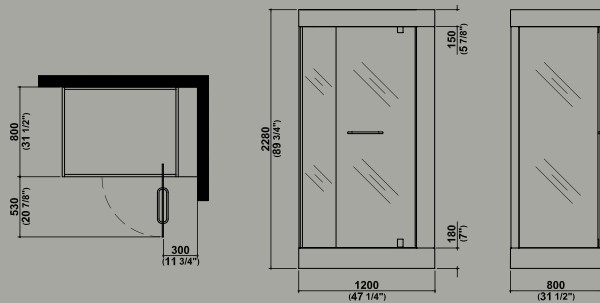

Atollo incasso sx/dx \_ built-in left/right hand

128, 129

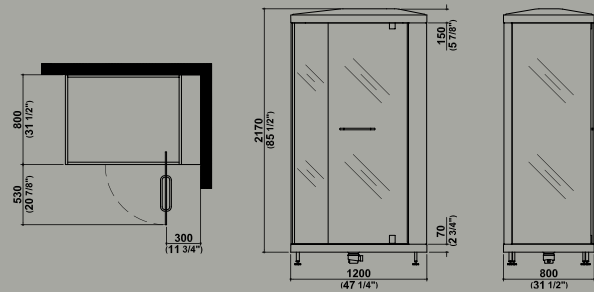



Avec Small

120, 121

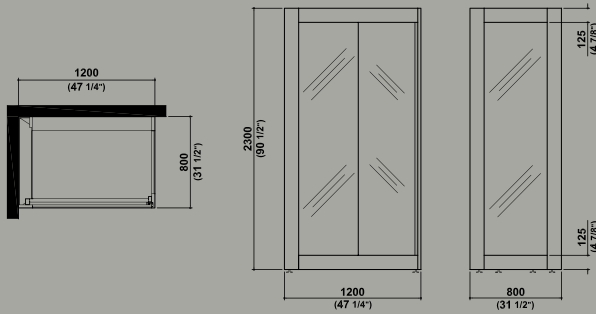

Avec Moi

111, 112, 113, 114, 115

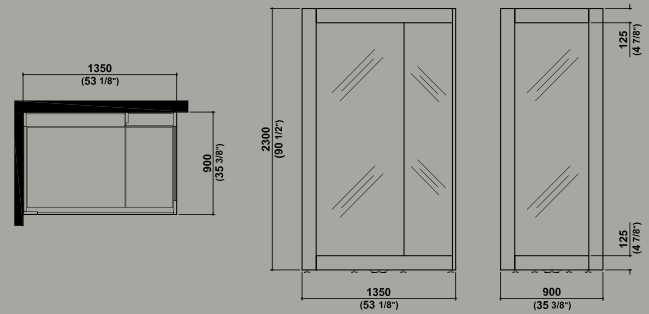

Avec Toi

116, 117, 118, 119

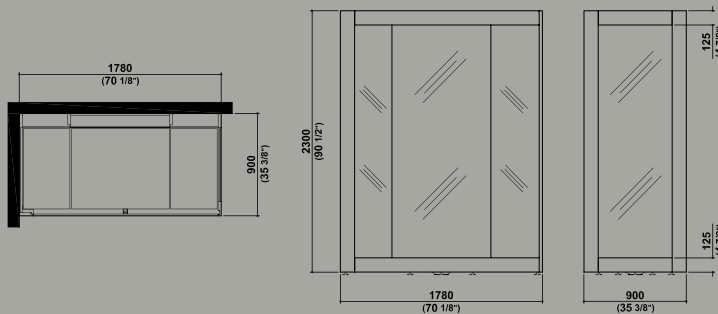

sgabello in legno iroko \_ iroko wooden stool

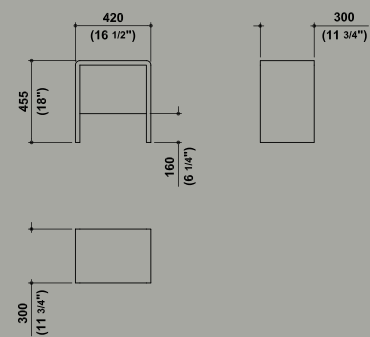



Floor 1 sistema doccia \_ shower system

134

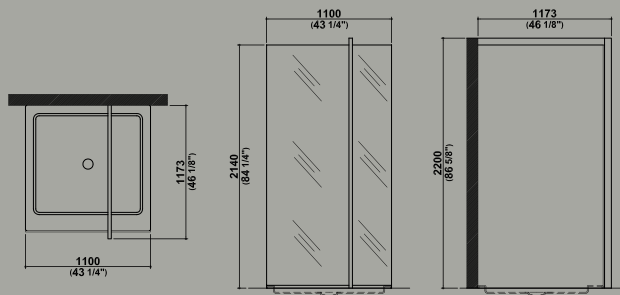

Floor 2 sistema doccia \_ shower system

135

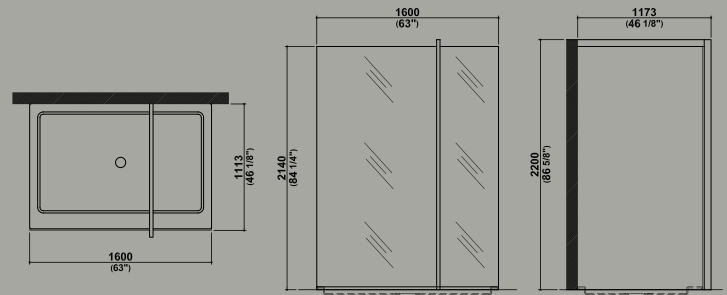

Geo tray 80

132, 133

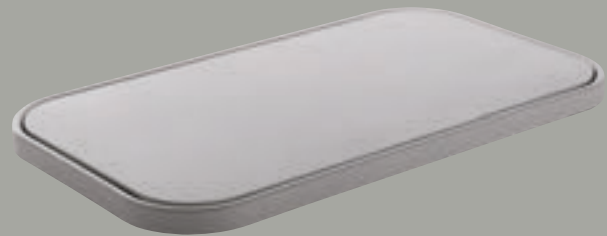
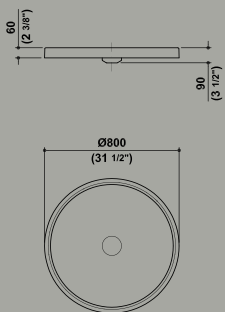

Geo tray

131

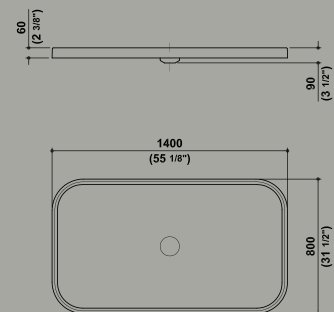

MORPHING / BATHTUBS

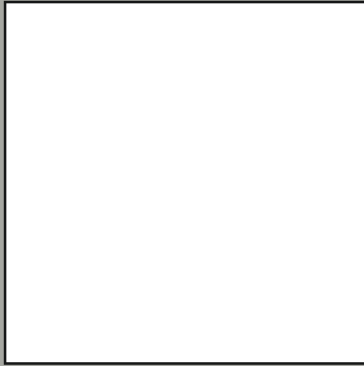

bianco  
white

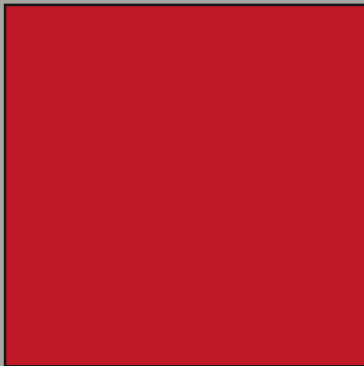

rosso Ral 3003  
red Ral 3003

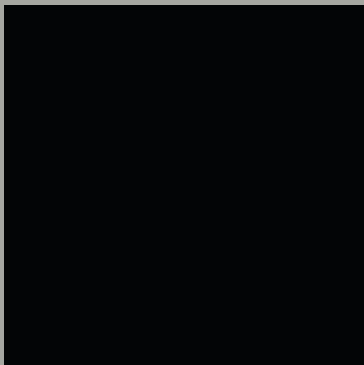

nero Ral 9005  
black Ral 9005

MORPHING / STEEL



bianco / bianco  
white / white

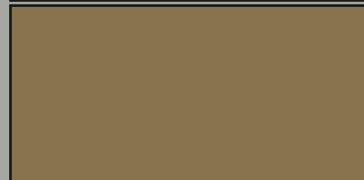

bianco / tortora  
white / dove

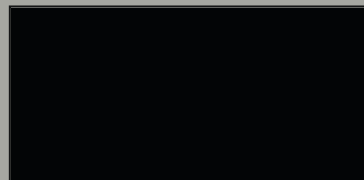

nero / nero  
black / black

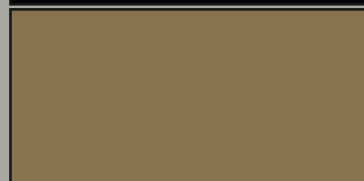
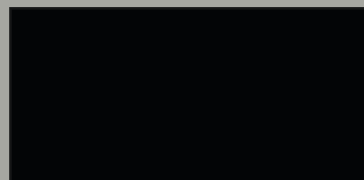
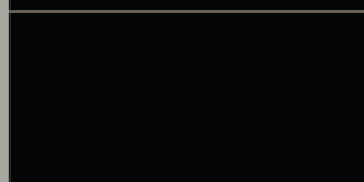

nero / tortora  
black / dove

MORPHING / UNIT

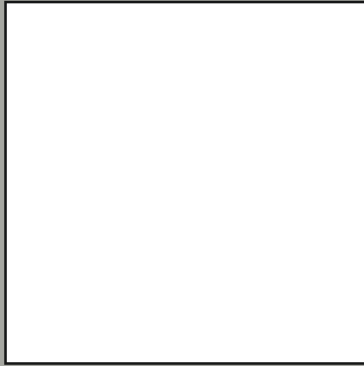

bianco  
white



ciliegio sbiancato  
limed cherry wood



wengè  
wengè

MORPHING / COMPLEMENTS

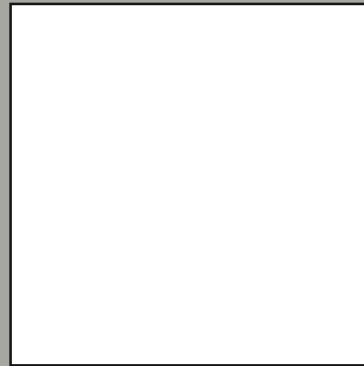

bianco laccato  
white lacquer



nero laccato  
black lacquer



AVEC SMALL/MOI/TOI

---

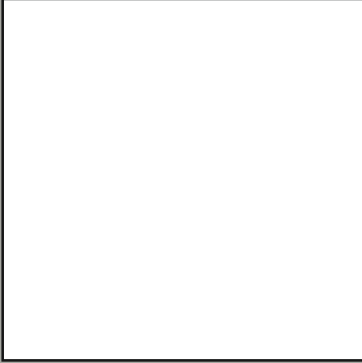

bianco opaco Ral 9010  
white matt Ral 9010

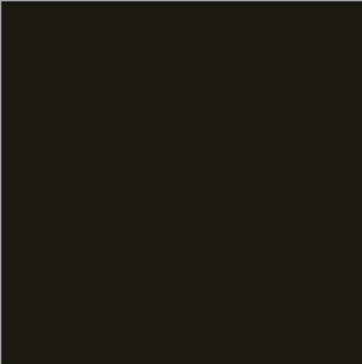

nero opaco Ral 9005  
black matt Ral 9005

COMPLEMENTI FARAWAY

---

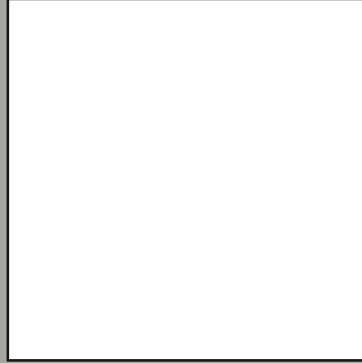

bianco Ral 9010  
white Ral 9010



azzurro Ral 5024  
light blu Ral 5024

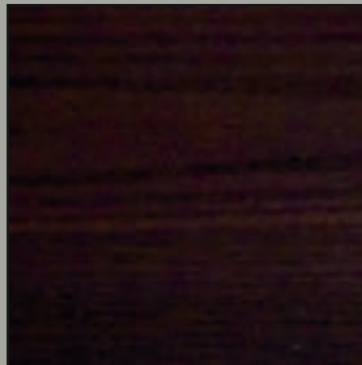

frassino termotrattato  
heat-treated ashwood





# KOS

Zucchetti Rubinetteria S.p.A.

Via Molini di Resiga, 29  
28024, Gozzano (NO)  
Italy

tel. +39 0322 954700

fax +39 0322 954823

[www.kositalia.com](http://www.kositalia.com)

[info@kositalia.com](mailto:info@kositalia.com)



#### CONCEPT, GRAPHICS & STYLING

ps+a

#### PHOTOS

Lorenzo Barassi  
Luca Fregoso, gfp, Maurizio Marcato,  
Max Zambelli, ps+a archive

#### TECHNICAL INFORMATION

Noah

#### COLOR SEPARATION & PRINT

Telligraf srl

#### THANKS TO

Airdiem, Alessi, Brix, Ceramica Sant'Agostino, Comfort Zone, Crespi Bonsai,  
David Sorgato, Driade, Elmar, Exteta, Ex Voto Paris, Fantechi, Flos, Foscarini,  
Georg Jensen, Gianni Vigone, Guaxs, Intentions, Iris Ceramica, Kenzo, Kvadrat,  
Luceplan, Nahoor, Oltrefrontiera, Swan, Pols Potten, Rapsel, Riva 1920, Sawaya &  
Moroni, Technogym, Tubes, Vetreria AT, Vetreria Vistosi, Vitra, Zanotta.

L'azienda si riserva in qualsiasi momento la facoltà di apportare tutte le modifiche  
necessarie al miglioramento estetico e qualitativo del prodotto.

The company reserves the right to make all the necessary changes for the purpose  
of constant improvement of quality, with no obligation to give prior notice.

2015



